

VALICHANGER OPERATIONS MANUAL SERIES AC400/500

American Changer Corp.
1400 NW 65th Place
Ft. Lauderdale, FL 33309

Parts & Service:(888)741-9840
Sales:(800)741-9840
Fax:(954)917-5204

Internet Address: www.americhanger.com

Service Questions?: E-mail: service@americhanger.com

Table of Contents

SECTION A: SET-UP & INSTALLATION

Uncrating & Setup _____	3
Mounting instructions _____	3-4
Filling the Hopper _____	4
Using the Dump Mode _____	4
Fuse _____	4
Functional Descriptions _____	5-6
Indicator Lights _____	6
Wiring definitions _____	6

SECTION B: VALIDATOR

INFORMATION _____	6-13
CoinCo Flash (Error) Codes _____	6
AC400 JCM Validator Info _____	6
AC400 removing a bill jam _____	7
AC500 clearing a bill jam _____	9
Setting the CoinCo dip switches _____	10-11
CoinCo Validator Cleaning _____	12

SECTION C: TROUBLESHOOTING

INFORMATION _____	14-16
Troubleshooting Guide _____	14
Technical Flow Diagram _____	15-16

SECTION E: PARTS LISTS

Parts Compact Hopper _____	17
AC500 Cabinet Parts Breakdown _____	18
AC400 Cabinet Parts Breakdown _____	19
CoinCo Parts Breakdown _____	20-23

*CoinCo branches and Service centers
are on the back cover of this manual.*

Rev. MIDI C-40 Jan'05

Specifications

Operating voltage	120 VAC +10/-15 %
Power consumpt.(controller only, add hopper and validator)	10w
Operating temperature	32 - 130 degrees Fahrenheit
Interface to Hoppers	24vdc & 12vdc 1.5 amps max.
Interface to Validators	120vac .5 amps max.

Warranty

AC 500 CoinCo BA30BAB Validator

The CoinCo Dollar Bill Validator is warranted for two years from date of purchase.

AC400 JCM DBV-10 Bill Validator is warranted for 1 year.

COVERED

¥ Defect in workmanship or material.

NOT COVERED

¥ Damage caused by physical abuse.

¥ Misapplication.

¥ Vandalism.

¥ End users attempt, on his own to repair item.

¥ Cleaning maintenance.

It is the End User's responsibility to follow cleaning maintenance procedure outline on page 12. Any unit coming in for repair requiring only a cleaning will be charged a flat rate of \$65.00 plus shipping and handling

Dispensing System and Logic Board

The dispenser and logic board is warranted for one year from date of purchase.

COVERED

¥ Defects caused by material or workmanship.

NOT COVERED

¥ Damage caused by physical abuse.

¥ Misapplication.

¥ Vandalism.

¥ End Users attempt, on his own to repair.

A Return material authorization number (RMA#) must be obtained before returning a unit for repair . A copy of invoices must accompany any and all warrantee work.

Attention Please:

To ensure the most trouble-free machine operation, we recommend plugging all our machines into a DEDICATED AC outlet. (This means there are no other machines on location plugged into the same AC line.) A simple way to check if this is true is to turn off the breaker at the fuse box associated with our machine. No other machines on location should lose power or turn off.

If this is a concern for your area of business, we recommend purchasing a surge protector locally
NOTE: A POWER STRIP IS NOT A SURGE PROTECTOR.

AC _____ S/N# _____

Tested By _____

Date _____

**Thank You,
American Changer Corp.**

UNCRATING AND SET-UP

Remove your Series AC400/500 changer from the shipping box. Open the door. (*The T-handle is the screw-in type and therefore, must be turned at least 10 times counter-clockwise until it opens.*) Inspect for any connectors or components that may have been dislodged during shipping. The lock and keys for your changer will be inside the manila envelope along with this manual. To install the locks, insert the cylinder into the round hole in the middle of the T-handle and push until they stop. Now turn the key and lock until you hear it "snap." Turn the key counter-clockwise ¼ turn and remove the keys.

NOTE: The only way to get a duplicate set of keys made is to save the red tag that comes between the keys. This ID # starts with "ACC #####".

Write your Key # here "ACC _____".

ALL KEY ORDERS TAKE 4-6 WEEKS!!!

TEST:

Before permanently installing the changer, do a functional test to verify that there is no shipping damage to your new changer(s).

Extend the power cord through the hole in the back of the changer or the bottom and plug it into a **grounded 120vac outlet**. The changer can only be set for a 4 coin per dollar pay-out of the hopper. The Bill validator is ready to accept \$1-\$5 dollar bills.

Fill the hopper with at least 50 coins. On the main logic board turn the switch on the bottom right corner "ON". (SEE FIG. 1 ON PG.3) *The rocker switch has a "1" and "0" printed on it. When the "1" is pressed down the changer is "ON".*

MOUNTING THE AC400/500 TO A WALL

IF YOU ARE UNSURE IN ANY WAY IN PROCEEDING WITH THE FOLLOWING STEPS, PLEASE HIRE A LOCAL PROFESSIONAL ELECTRICIAN TO MOUNT YOUR CHANGER FOR YOU!

1. Disconnect any and all AC power going to the changer. (See fig. 1)
2. Slide the hopper out of the cabinet.
3. Note: You will need to verify with the building code that it is allowable to plug the changer into a 3 prong grounded outlet. If it is not, there must be 120VAC run through conduit to the changer. If it is not required, proceed to step #6.
4. Let the electrician run the conduit, install the new breaker, wire and help decide how the wiring will enter the changer (from the back or the bottom). This will affect the mounting location.
5. After the conduit has been installed, proceed with the mounting.
6. Locate the 4 punch-outs on the back wall of the changer. Using a screwdriver and hammer knock the punch-outs out by hitting them from the inside of the changer.
7. Using a stud locator, find a location to hang the changer by locating the wall studs.

8. Find an appropriate wall to bolt the changer into. The wall should have studs or be constructed of concrete. Consult a professional with any questions you may have.
9. **NOTE: HANGING THE CHANGER FROM LESS THAN ALL 4 HOLES MAY BE DANGEROUS. EACH HOLE NEEDS A BOLT THROUGH EACH ONE MOUNTED SECURELY TO THE WALL. MOUNTING THE CHANGER IN ANY OTHER WAY MAY RESULT IN THE CHANGER BEING TORN OFF OR FALLING OFF THE WALL RESULTING IN PERSONAL OR CUSTOMER INJURY ALONG WITH ELECTRICAL SHOCK.**
10. Choose a height to mount the changer keeping in mind that a handicapped person in a wheelchair should still be able to insert a bill into the bill validator. (We recommend no higher than 4 feet above the ground.)
11. Have someone hold the changer against the wall while someone else marks the holes. **CAUTION: THE CHANGER WEIGHS 40 POUNDS DO NOT EXERT YOURSELF SO THAT YOU MAY CAUSE AN INJURY.**
12. **BEFORE DRILLING THE FOUR MARKED HOLES ENSURE THAT THERE ARE NO ELECTRICAL WIRES, TELEPHONE LINES, GAS, OR WATER LINES BEHIND THE WALL WHICH DISRUPTING MAY CAUSE A LOSS OF LIFE OR PERSONAL INJURY!**
13. Hold the changer back up to the wall. Thread and tighten bolts.
14. Verify that the machine is securely mounted.
15. If the changer is permanently connected through a conduit, proceed to step #17.
16. Feed the AC line cord out the bottom or the back of the changer then perform the following.
 - A. Plug the male end into the AC wall outlet. ***Do not use an extension cord unless allowed by the building electrical code.***
 - B. Installation is finished and you can proceed to the "Filling the Hopper" section.
17. In order to continue you will need to purchase numerous electrical components. We highly recommend HIRING a qualified electrician to perform the following!
 - A. Install the conduit box on the conduit entering the cabinet in the lower right side of the cabinet.
 - C. Secure the 3 wires (hot, neutral, and ground) to the AC wall outlet and the ground wire should also be directly attached to the cabinet ground terminal.
 - D. Plug the male end into the AC outlet just installed.
18. Proceed to the "Filling the Hopper" section.

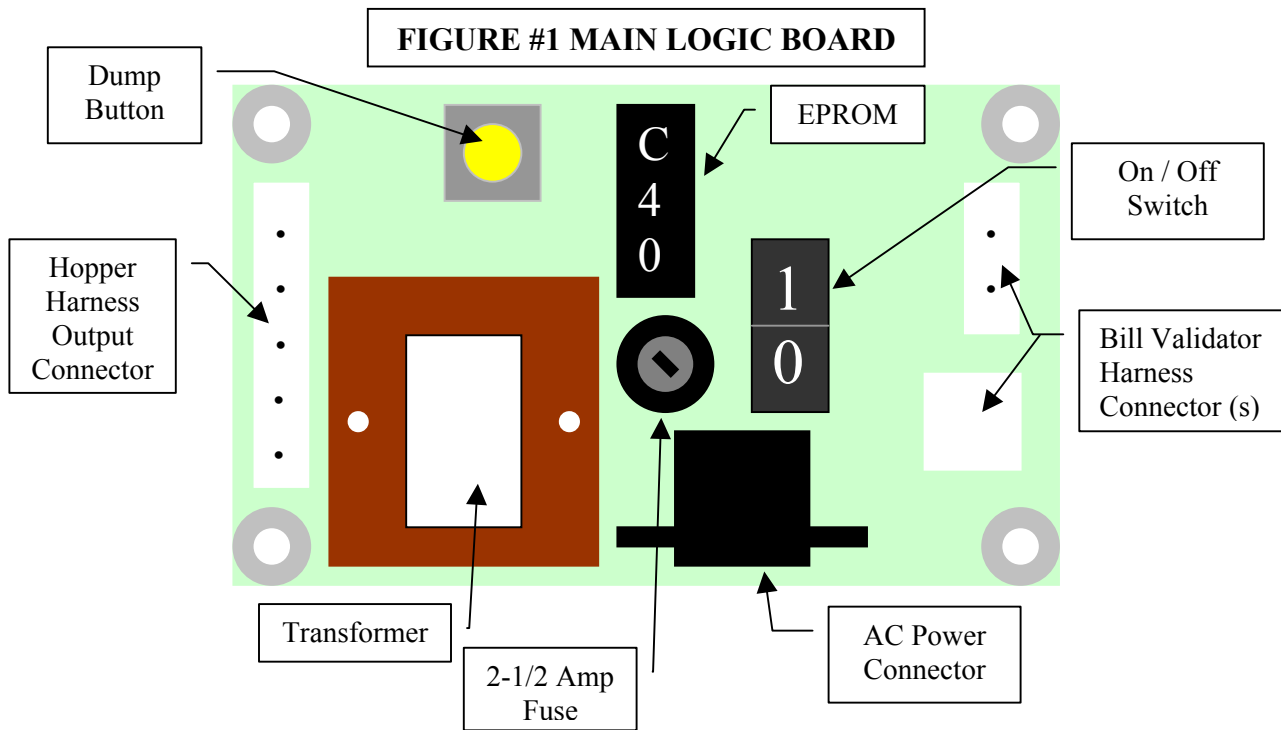

FILLING THE HOPPER

When the hopper has less than 40 - 50 coins left in it the red "Empty" LED will light on the front of the changer. If you have disconnected your LED, make sure the orange wire is going to the terminal on the LED that has the red positive mark next to it. Whenever the "Empty" LED is "ON" the validator is disabled and it will no longer accept bills.

1. Turn OFF the power on the main logic board.
2. Slide the hopper out from the cabinet and insert the coins through the opening on the top. *There must be at least enough coins to cover the two copper plates at the bottom of the hopper. (Somewhere between 40 and 1000 coins minimum to maximum.)*
3. Slide the hopper back into the hopper plate. **Do not use excessive force!**
4. Turn "ON" the power switch. The "Empty" LED is now off and the bill validator is ready to accept bills.

USING THE DUMP MODE TO EMPTY THE HOPPER

1. Open the cabinet door.
2. Turn OFF the POWER switch.
3. Place a suitable container in front of the hopper to catch the coins.
4. Press and hold the "DUMP" button on the upper left corner of the Main Logic Board. Turn ON the Power switch. The red LED on the main logic board will come on then go off. Once the red LED goes off, release the "DUMP" button. If it is not released within two seconds, the "DUMP" mode is canceled as a security feature. The hopper will dispense coins until the POWER switch is turned OFF. If the Red LED on the Main Logic Board is not flashing 3-5 times per second the dump mode was not accessed. Please try again.

FUSES

High voltage fuse: This is the primary transformer AC fuse for the main logic board and the validator. Any direct short of the Transformer or validator will cause this fuse to blow. Replace this fuse with a 2-½ amp AS fuse only. ***REPLACING THIS FUSE WITH ANYTHING OTHER THAN A 2 ½ AMP "AS" MAY RESULT IN A FIRE OR AN UNSAFE WORKING CONDITION!!*** (See fig. 1 for location of this fuse.)

Low voltage fuse: This is the secondary transformer fuse for the 5 - 28 vdc sections of the main logic board and hopper. It is located to the left of the transformer. (See fig. 1) Replace this fuse with a 2-½ amp AS fuse only. ***REPLACING THIS FUSE WITH ANYTHING OTHER THAN A 2 ½ AMP "AS" MAY RESULT IN A FIRE OR AN UNSAFE WORKING CONDITION!!***

Functional Description of the Series AC400/500 Changer

To follow along with this walk-through of your changer, fill the hopper with coins and turn the changer on.

1. When power is applied the validator will cycle twice. The out-of-service LED flashes then goes out. The green LED on the main logic board comes on steady, and the red LED on the main logic board will light then go off then flicker on once per second in the standby mode.
2. During the power-up mode the main logic board relay clicks twice enabling power (120vac) to the validator. When this relay is not enabled it routes 12vdc ground to the out-of-service LED. Without power to the validator the changer cannot accept bills. Since we are not in the error mode, the red LED on the validator logic board is on steady.

3. When a bill is inserted into the validator bill slot, the bill will be pulled inside. The validator then compares what the bill looks like to its memory. After the bill is validated it grounds the 5vdc lines causing a pulse along the yellow and blue validator harness wires to pins 5 and 6 of the main logic board. Each pulse stands for the amount of the denomination validated. (i.e. 1 pulse for \$1, 5 pulses for \$5).
 4. The 5vdc pulse then travels from pins 5 and 6 to the EPROM chip (ver. MIDI C-40) pin #8. The EPROM multiplies the bill pulse by 4.
 5. The EPROM then sends the hopper pulses out pin #18 to pins 6 and 7 of the red 12-pin hopper plug. These pulses travel through the purple and brown wires of the hopper wire harness to the hopper.
 6. The EPROM turns the hopper on. The hopper optic counts the coins out and sends them to the EPROM chip on pins 8 &9. When the amount of hopper pulses in equals the coins dispensed through the coin counting optical sensor, the EPROM turns the hopper off.
 7. The Changer returns to the standby mode with the red LED flashing once per second until another bill is inserted.
3. **Validator Fault:** When a validator fault occurs the validator's EPROM shuts down the validator and flashes an error code via the red LED on the validator logic board. When there is no error this LED is on steady. The validator only gives bill pulses to the main logic board so the main board never knows if the validator isn't functioning. Therefore the out-of-service-LED will not light. (See page 6 for validator error codes.)
 4. **Low Coins:** The low coin condition is probably the most common fault. The EPROM on the main logic board is constantly checking for low coins in the hopper. This is done with a low current 5vdc signal on pin #3 of the hopper output connector. The voltage then travels down the hopper wire harness on the white wire to pin #7 of hopper plug. The signal is applied to one of the gold low contact plates at the bottom of the hopper. The 5v travels through the coins through the other contact gold plate to hopper pin #2. It then goes through the black wire in the hopper harness to pin #10 on the main logic board. Any interruption of more than 1/2 a second will cause an out-of-service condition.
 - A. Clean the bottom copper plates of the hopper with steel wool or fine sandpaper. Refill the hopper and try again.
 - B. Check continuity, (0 ohms) resistance, from pins 3 (white) and 10 (black) of the red hopper harness. Make sure the hopper full and the changer turned off. If the continuity is 0 ohms, replace the main logic board.
 - C. Pull the hopper out of the changer, then look at the 12 pin black male connector that sticks out of the hopper. Place the continuity checker's leads on pins 2 & 7.
 1. If the continuity is 0 ohms, replace the hopper plate or adjust the hopper plate's female socket's pins so that they are not so spread out.
 2. If the continuity is infinity, then replace the hopper.

Functional Descriptions of Out-of-Service Conditions

Out-of-Service conditions occur for the Series AC400/500 changer for the following reasons; low coins, hopper fault error, validator fault, or a blown fuse.

1. **Blown Fuse:** an AC power spike in line voltage or a bad transformer on the main logic board can cause A blown fuse on the main logic board. If the fuse blows the indication is the green LED on the main logic board will not light.
 - A. Replace the fuse. If the green LED now lights then there was a spike.
 - B. If it does not and the fuse blows again the power transformer is shorted. To test the transformer use a voltmeter set for ohms and measure across the primary (40ohms) and the secondary (1.5ohms).
2. **Hopper Fault:** A hopper fault can either be a jammed hopper, a blocked coin counting optic or a bad hopper logic board.
 - A. Indications for a jammed hopper are the changer accepts bills, the meter counts up, but nothing or not enough coins are paid out.
 1. After 1 minute the "Empty" LED on the outside of the cabinet turns on and the validator is shut off.
 2. At this point the three options open are to attempt repair on your own, call your distributor, or return the hopper to American Changer.
 - B. Indications for a blocked coin optic or bad hopper logic board are the out-of-service LED on the outside of the changer is lit and the red LED on the main logic board is lit and flickers off once per second.

Indicator Lights

AC500 ONLY!

Main Logic Board:

1. Green LED on: AC power applied to the logic board. All fuses are good.
2. Red LED
 - A. Heartbeat - 5 and 12vdc present. The changer is in standby waiting for a bill pulse.
 - B. On Steady - Out of service, Hopper error detected.

Validator logic board:

1. Red LED
 - A. On Steady - Standby Mode, waiting for bill insertion.
 - B. Flashing - Error mode, go to page for error code information.
 - C. Off - The changer "Empty" LED is lit.

WIRE HARNESS COLOR AND DEFINITIONS

Validator harness:

- Red - Switched Hot 120VAC.
- White - Neutral 120VAC.
- Black - 120VAC Low current validator enable.
- Yellow - +5vdc credit pulse line.
- Blue - -5vdc credit pulse line.
- Orange - +12vdc Empty LED.
- Brown - -12vdc Empty LED.

Hopper Harness

- Yellow - Coin counting optic status line.
- White - Low coin sense (+5vdc).
- Brown - Low coin sense (-5vdc).
- Black(s) -- 24vdc Motor supply voltage.
- Orange - +24vdc Motor supply voltage.

CoinCo MAGPRO Series Flash Codes

Flash codes 1-18 may appear during normal servicing of the BA30. If more than one error or condition exists, the lower number flash code will appear until its respective error or condition is corrected. The left and right sensors referenced below are given viewing the BA30 from the front.

# of Flashes	Description of Flash Codes
1	Bill box full
2	N/A
3	Check bill path
4	All bill accept switches are off
5	Bill jam or sensor error
6	Stacker motor/home sensor
7	Transport motor/encoder sensor
8	N/A
9	EPROM Has Failed
10	EPROM Has Failed
11	Center Optic Failed
12	Right Optic Failed
13	Left Optic Failed
14	Bill Position Sensor Error
15	Right Bill Position Sensor Error
16	Left Bill Position Sensor Error
17	Lower Anti-Stringing Armature out of place
18	Upper Anti-Stringing Armature out of place

SETTINGS FOR THE AC400 ONLY!

4. Setting the DIP switches

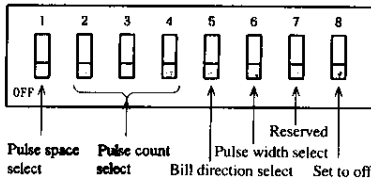

Setting the Pulse space

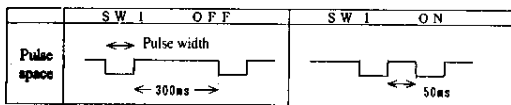

Setting the Phase count

	SW2	SW3	SW4
1 pulse/\$	OFF	OFF	OFF
2 pulses/\$	ON	OFF	OFF
3 pulses/\$	OFF	ON	OFF
4 pulses/\$	ON	ON	OFF
5 pulses/\$	OFF	OFF	ON
8 pulses/\$	ON	OFF	ON
10 pulses/\$	OFF	ON	ON
20 pulses/\$	ON	ON	ON

Setting the Bill direction

SW5 OFF : 2 way
ON : 1 way

Setting the Pulse width

SW6 OFF : 50 ms
ON : 450 ms

AC400 BILL VALIDATOR CLEANING AND UN-JAMMING

8. When the Acceptor is jammed

Loosen thumb screws on both sides of the Acceptor.

Use a coin in case thumb screws are tight.

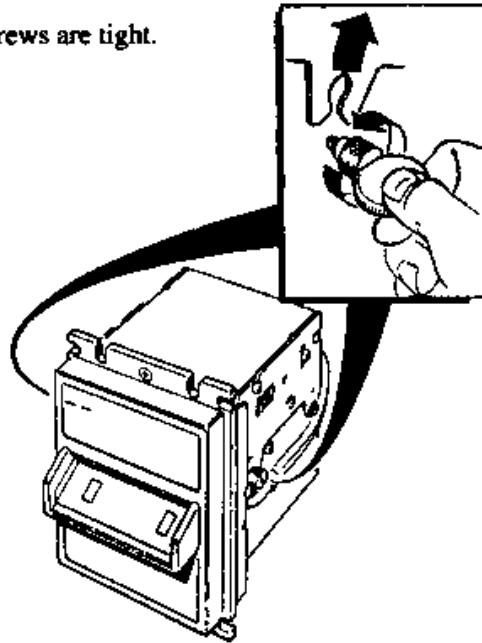

9 Lift the upper cover to remove the bill

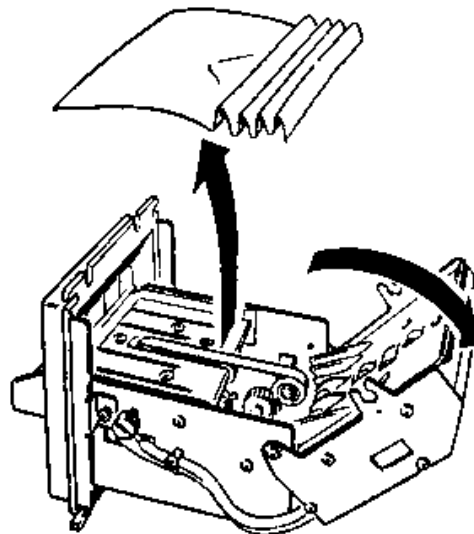

MAG BILL ACCEPTOR

Operation and Service Manual



COINCO MAG50 VALIDATOR SECTION

	PAGE
Removing the Bill Box	9
Clearing a bill jam	9
Setting the bill types accepted	10
Cleaning the sensors	11
Cleaning a salted unit	12
Replacing the belts	13



Removing the bill box.

To remove the 500 bill stacker from the CoinCo validator follow the picture below.

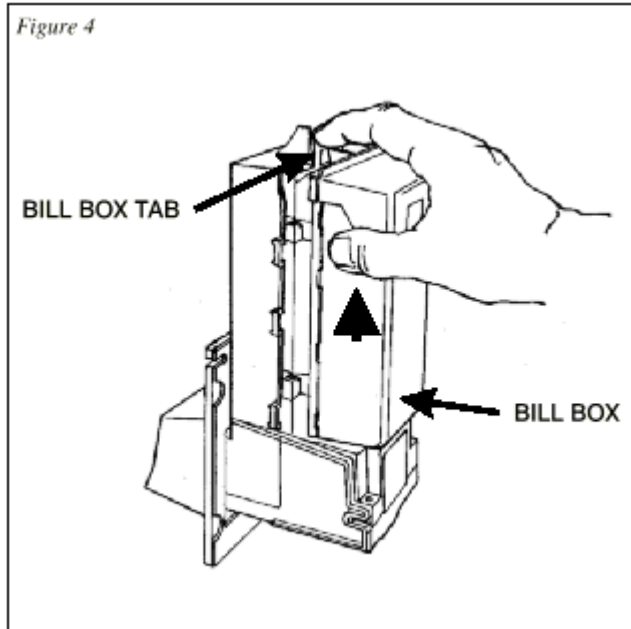

REMOVING A BILL JAM

From time to time a foreign object or ripped bill will become caught in the validator. Follow the picture below to remove the item.

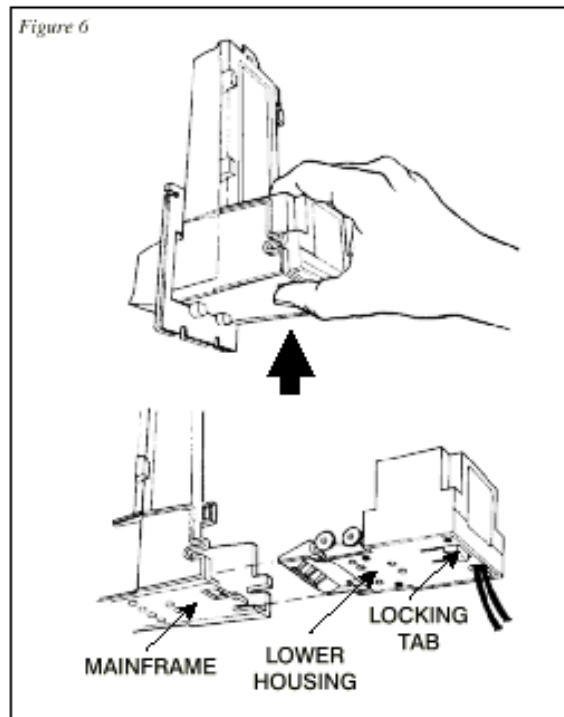

SETTING THE BILL ACCEPT DIP SWITCHES

Figure 1

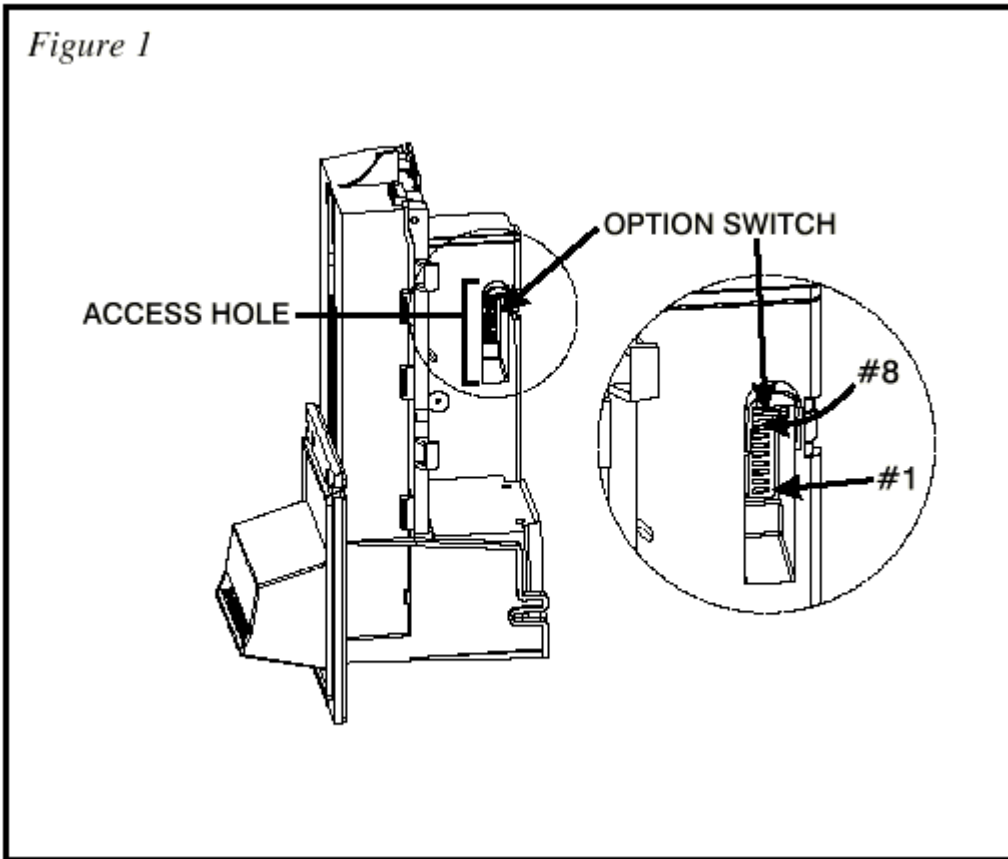
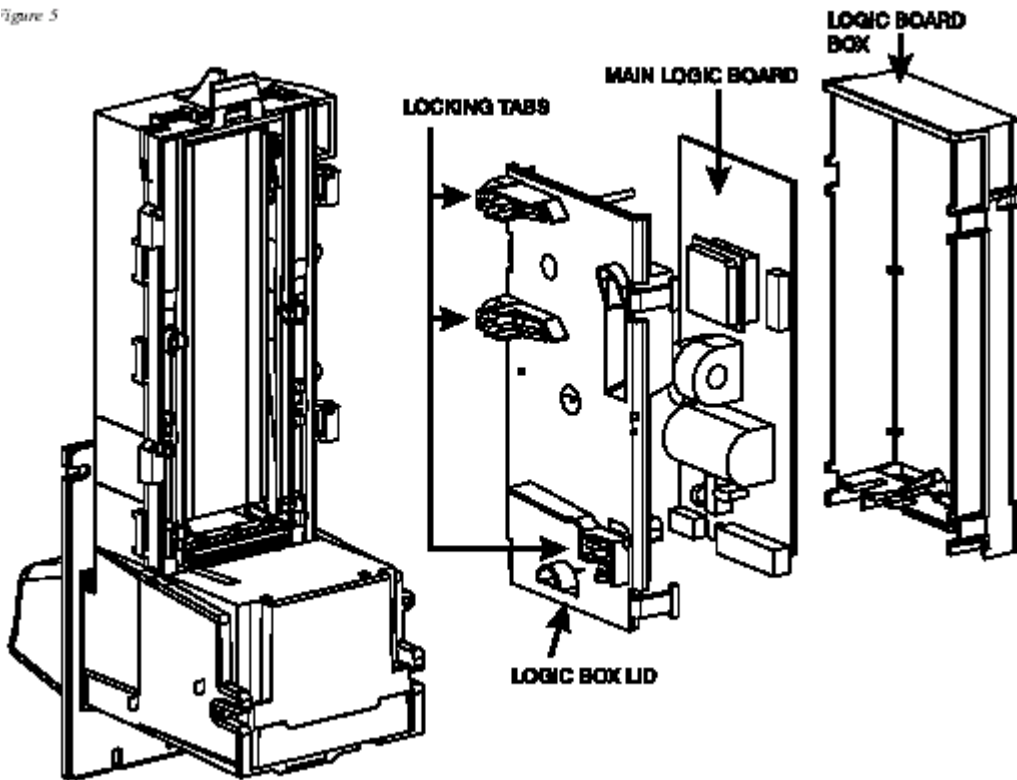
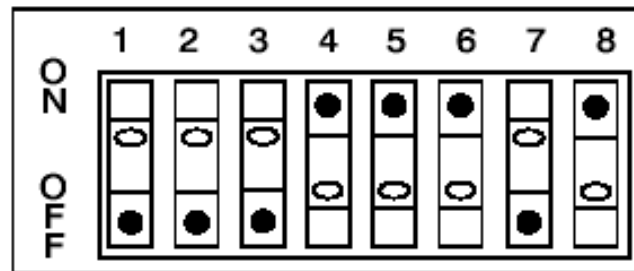

Figure 5



SWITCH	ON	OFF
1	High Security	Standard Acceptance
2	Accepts bills in one directions only (face up, green seal first)	Accepts bills in both directions (face up)
3	Standard credit pulse 150ms on 150ms off	Short credit pulse 50 ms on 50 ms off
4	\$20 Accept	\$20 Reject
5	\$10 Accept	\$10 Reject
6	\$5 Accept	\$5 Reject
7	\$2 Accept	\$2 Reject
8	\$1 Accept	\$1 Reject



CLEANING THE BILL VALIDATOR

Refer to the pictures and the procedure on the next page to clean the bill validator every 4-6 months.

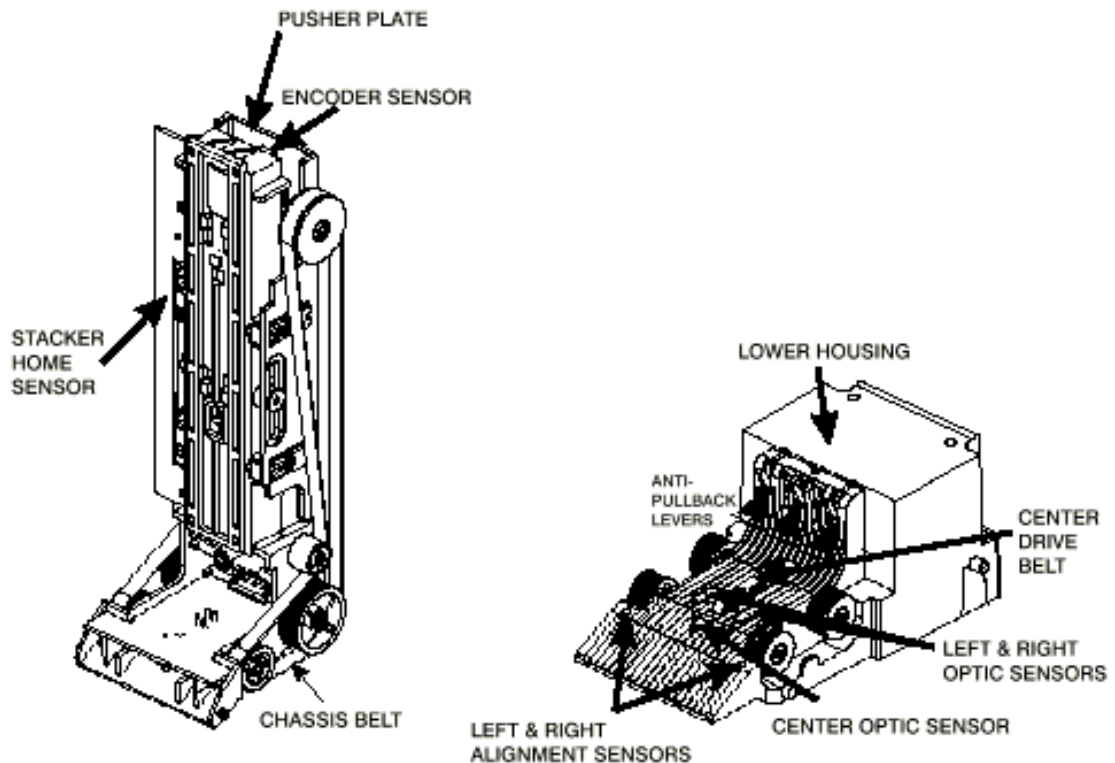

MAGPRO CLEANING: IF ANY OF THESE PROCEDURES ARE PERFORMED TO YOUR VALIDATOR AFTER IT IS RETURNED UNDER A WARRANTY REPLACEMENT, YOU WILL BE SUBJECTED TO A \$65.00 LABOR FEE.

CLEANING AND MAINTENANCE:

Note: *Petroleum-based cleaners and freon-based propellants can damage plastic and some electronic components. Scouring pads and stiff brushes may harm the protective conformal coating on the circuit boards and can mar the plastic. These items should never be used when cleaning the MAGPRO bill acceptor.*

The MAGPRO should be cleaned every 7,000 bills or every 4 -6 months (or as needed, depending on the environmental conditions of the location). Dust can be removed with a soft brush or cloth or it can be blown out using compressed air.

Procedure:

1. Disconnect power from the bill acceptor.
2. Remove the bill box and use a soft cloth to wipe the dust from around the intermediate frame and stacker plate.
3. Remove the lower track.
4. Using compressed air or a soft brush, blow or brush the dust off of the optic sensors and out of the recessed sensor openings.
5. Remove dust from around the belts and wheels on the lower housing and the sensors on the upper sensor board. The upper sensors are located directly above the lower housing sensor when the lower housing is installed.
6. The bill path can be cleaned to remove further dirt and oil using a soft cloth moistened with a mild soap and water solution.
7. Clean the magnetic head using a swab and isopropyl alcohol.
8. Once the lower housing is dry, place it back into the mainframe so that the tab on the bottom locks into place.
9. Blow the dust out of the encoder wheel and its sensors. (It may be necessary to extend the stacker plate to access the encoder wheel. Supplying power to the unit momentarily can do this, so that the stacker plate extends.)
10. Remove dust from the transport belt areas and from any other places of build up.
11. Remount the bill box.
12. Apply power and insert bills to verify that the unit is functions property.

MAGPRO CLEANING PROCEDURE FOR SALT WATER POLLUTED UNITS:

Note: *Petroleum-based cleaners and freon-based propellants can damage plastic and some electronic components. Scouring pads and stiff brushes may harm the protective conformal coating on the circuit boards and can mar the plastic. These items should never be used when cleaning the BA30 bill acceptor.*

Procedure:

1. Remove power from the bill acceptor.
2. Remove the bill acceptor from the vending machine.
3. Open the bill box lid and verify that the stacker plate is in the stand-by/home position. If it is not in the home position, apply power and observe that the stacker plate returns home.

Warning: *If moisture is present, allow the unit to dry thoroughly before applying power to avoid possible shock hazard. If the stacker plate does not return to the home position, remove power and carefully remove the bill box to avoid damaging the bill box and/or stacker plate.*

4. Remove the lower housing.

5. Remove the bottom cover from the lower housing.
6. Run hot water (1101/4-1401/4F) over the lower housing from the top and bottom. Using a soft brush, gently clean any residual salt. Use a soft absorbent cloth to clean any residue off the lower housing. If the transformer gets wet, allow the unit to dry for 24 hours before applying power.
7. Remove the front mask. Using hot water and a soft brush, clean the front mask, upper sensor board, main frame anti-pullback levers and position sensor mount.

Caution: The motors are not protected from water, therefore the unit must be held in a manner that prevents water from running over the intermediate frame crossbar.

8. Remove the position sensor cover on the crossbar and carefully lift the LED from its mount. (Early models only.)

Caution: Protective coating on the LED leads should not be damaged. Clean all salt residue from the mount, sensor hole and detector area.

The detector can be seen through the sensor hole, and is located in the chassis. Replace the position sensor cover. (Early models only.)

9. Verify that the anti-pullback levers move freely and that the spring returns them to their open position.
10. Allow the unit to dry thoroughly.
11. Clean the magnetic head using a swab and isopropyl alcohol.
12. Replace the front mask
13. Replace the lower housing cover.
14. Replace the lower housing into the main frame.
15. Remount the bill box.
16. Apply power and insert bills to verify that the unit is functioning properly.

6 OR 7 ERROR CODE FLASHES

The cleaning procedure for this common occurrence is listed below. Just follow these steps.

1. If this code has occurred on a new machine or one that the validators DIP switches were just changed, Ensure that all the white plugs on the side of the validator board away from the red LED are plugged in securely.
2. Remove the bill box.
3. Turn the Changer ON then OFF in an attempt to stop the metal push plate so that it COASTS into the fully outward position.
4. Using an air compressor or a can of compressed air blow out the area behind the push plate until it is completely free of all dust and lint.
5. Turn the changer power back on so that the push plate returns to the inward position. If the same error code persists, repeat steps 1 - 3 concentrating on the top center area behind the plate.
6. Replace the bill box.

REPLACING THE BELTS

Every 2-3 years the belts on the CoinCo will wear out. To replace them, remove the validator components down to the picture show. Refer to the parts diagram at the end of the manual for help getting to this point.

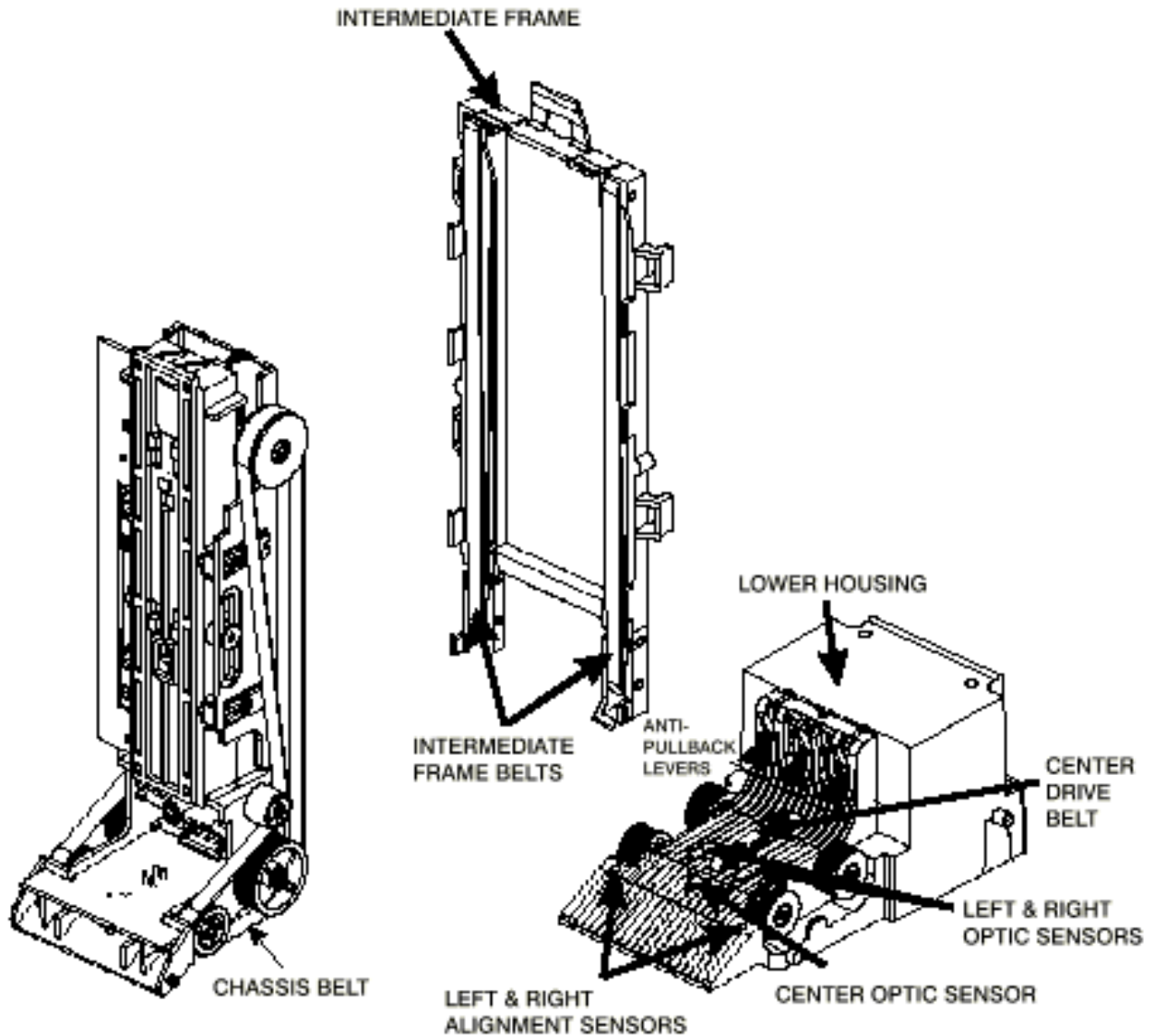

TECHNICAL FLOW DIAGRAM FOR THE AC400/500

*NOTE: Before starting this procedure ensure the changer is plugged in, the ON/OFF switch is on, the hopper is full of coins, and all wire harnesses are connected securely and correctly.
The wires exiting the red connectors should point away from the board!*

Start Here!

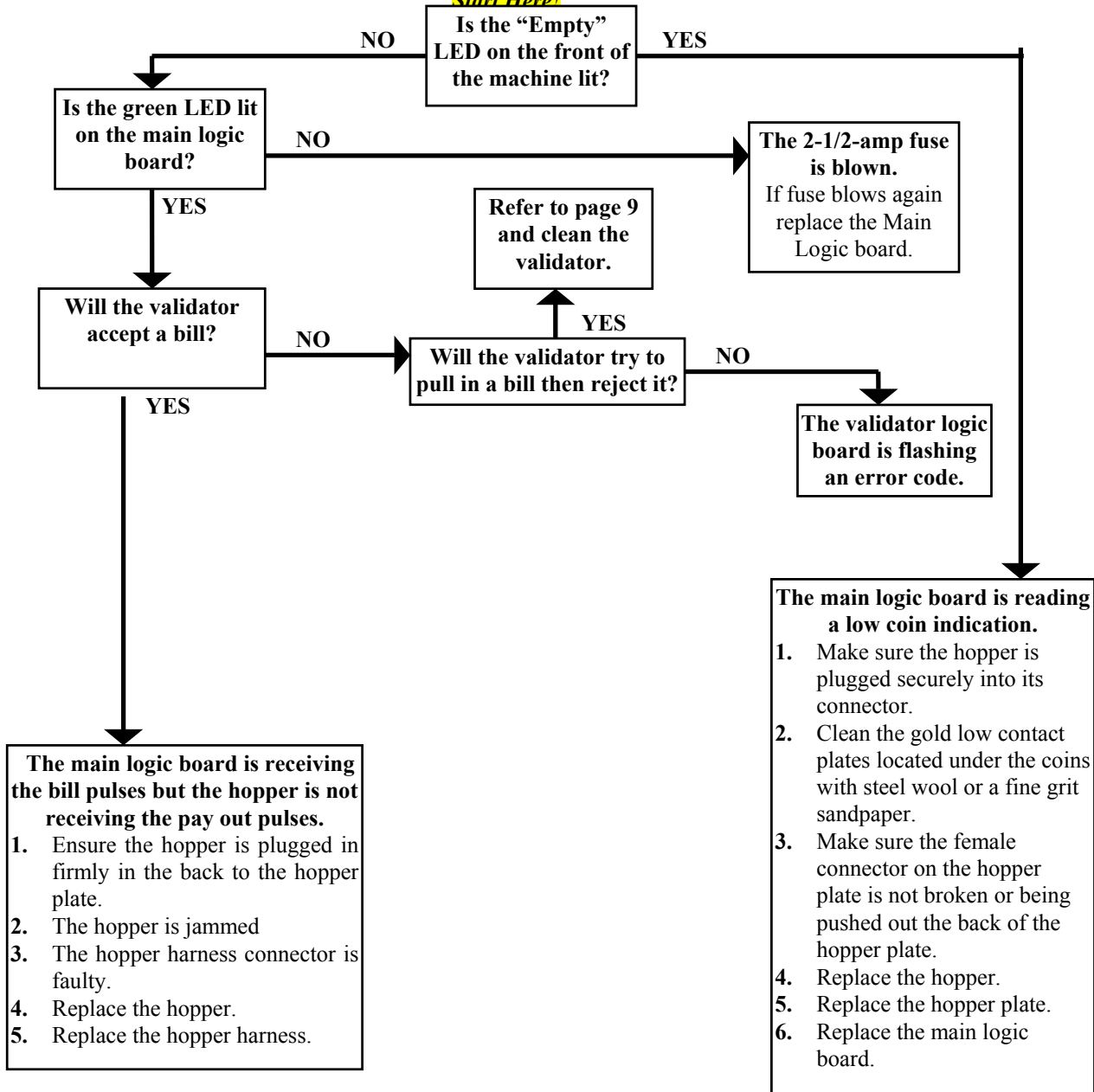

For a more detailed trouble shooting information proceed to the next section!

**FOR TECHNICAL SERVICE OR TO OBTAIN A RETURN AUTHORIZATION NUMBER
CALL (888) 741-9840**

ANY REPAIR RETURNED WITHOUT A RETURN AUTH. # WILL BE REFUSED!

TROUBLESHOOTING GUIDE

TO USE THE TROUBLESHOOTING GUIDE, MATCH UP THE PROBLEM, THEN FOLLOW THE SOLUTION SUGGESTIONS. After every step re-try operating the changer to see if the problem has been solved.

<i>Problem:</i>	<i>Solution:</i>
<p>A. The changer is completely dead. (The green LED on the main logic board is not lit.)</p>	<ol style="list-style-type: none"> 1. Ensure the changer is plugged in. 2. Ensure the on/off switch is rocked to the (1) position (down). 3. Unplug the female end of the line cord from the main logic board AC connector and plug it in again tightly. 4. Measure the AC voltage at the outlet or check the breaker/fuse box. You can also plug another item into the AC wall outlet to ensure there is power present at the outlet. 5. Inspect the AC line cord for cuts or abrasions. 6. Check both fuses on the Main Logic Board. 7. Replace the main logic board. 8. Replace the line cord.
<p>B. The “Empty LED is lit.</p>	<ol style="list-style-type: none"> 1. Ensure the hopper is not out of coins. (There should be enough coins in the hopper to cover the gold low-level contact plates. These plates are located at the bottom of the hopper where you pour the coins.) 2. Check the hopper wire harness that extends from the back of the plate that the hopper slides in and out on for chipped pieces or other damage. (Pay close attention to pins # 2 & 7.) 3. Clean the copper contact plates with steel wool. 4. Replace the hopper. 5. Replace the hopper wire harness.
<p>C. The bill validator accepts a bill. The hopper does not pay out and the “Empty” LED comes on after 45 seconds.</p>	<ol style="list-style-type: none"> 1. The hopper is jammed. Take the hopper apart and remove the foreign object or bent coin from the green hopper turntable. 2. Replace the hopper. 3. Replace the hopper plate.
<p>D. The green LED on the main logic board is lit but the red LED never lights.</p>	<ol style="list-style-type: none"> 1. Bad 5 or 12vdc regulator on the main logic board. 2. The hopper is shorted. 3. Replace main logic board. 4. Replace hopper.
<p>G. Bill validator will not pull in the bill and the “Empty” LED is not lit.</p>	<ol style="list-style-type: none"> 1. Ensure the orange wire going to the “Empty” LED is connected to the + or the terminal with the red mark by it. 2. Check for 12vdc going to the orange and brown wires. If there is, replace the LED. 3. Replace the main logic board. 4. Replace the bill validator. 5. Replace the validator wire harness.
<p>H. The bill validator pulls in the bill slightly then rejects it.</p>	<ol style="list-style-type: none"> 1. Clean the validator. (pg. 12) 2. Remove the lower housing (pg. 10) of the bill validator. Ensure the center wheel spins freely. Push straight down on it slightly to loosen.

TROUBLESHOOTING GUIDE

TO USE THE TROUBLESHOOTING GUIDE, MATCH UP THE PROBLEM, THEN FOLLOW THE SOLUTION SUGGESTIONS. After every step re-try operating the changer to see if the problem has been solved.

PROBLEM:	SOLUTION:
I. The bill validator red status LED flashes a “5” error code. <i>(AC500’S ONLY!)</i>	<ol style="list-style-type: none"> 1. Clean the validator optic LED’s. (See pg. 12) 2. Ensure that all the wire harness plugs are plugged firmly into their white female sockets. 3. Turn to the back page of this manual and check for a Coin Acceptors branch in your area to repair your bill validator.
II. The bill validator red status LED flashes a “6 or 7” error code. <i>(AC500’S ONLY!)</i>	<ol style="list-style-type: none"> 1. Take the bill stacker off the bill validator. Cycle the power on / off using the switch on the main logic board and coast the silver push bar so that it stops in its fully extended position. Blow out the area behind the push bar with high pressure or canned air. Concentrate on the encoder wheel in the area top center behind the push bar. 2. Turn to the back page of this manual and check for a Coin Acceptors branch in your area to repair your bill validator.
J. The bill validators red status LED is on steady but it still will not accept the bill. <i>(AC500’S ONLY!)</i>	<ol style="list-style-type: none"> 1. Pull out the lower housing, see page 5, and look for something obstructing the bill path. (I.e. gum; paper tickets, coins, etc.) 2. Look inside the Plexiglas case on the side of the bill validator. Ensure that all the wire harness plugs are plugged firmly into their white female sockets.
K. The red “empty” LED on the outside of the changer is on, the red status LED on the main logic board is flickering on and off normally, and the hopper is full of coins.	<ol style="list-style-type: none"> 1. Ensure the hopper is not out of coins. (There should be enough coins in the hopper to cover the gold low-level contact plates. These plates are located at the bottom of the hopper where you pour the coins.) 2. Check the hopper wire harness that extends from the back of the plate that the hopper slides in and out on for chipped pieces or other damage. (Pay close attention to pins # 2 & 7.) 3. Clean the gold contact plates with steel wool. 4. Replace the hopper. 5. Replace the hopper wire harness.
FOR TECHNICAL SERVICE OR TO OBTAIN A RETURN AUTHORIZATION NUMBER CALL (888) 741-9840	<u>ANY REPAIR RETURNED WITHOUT A RETURN AUTH. # WILL BE REFUSED!</u>

COIN CONTROLS COMPACT HOPPER PARTS LIST

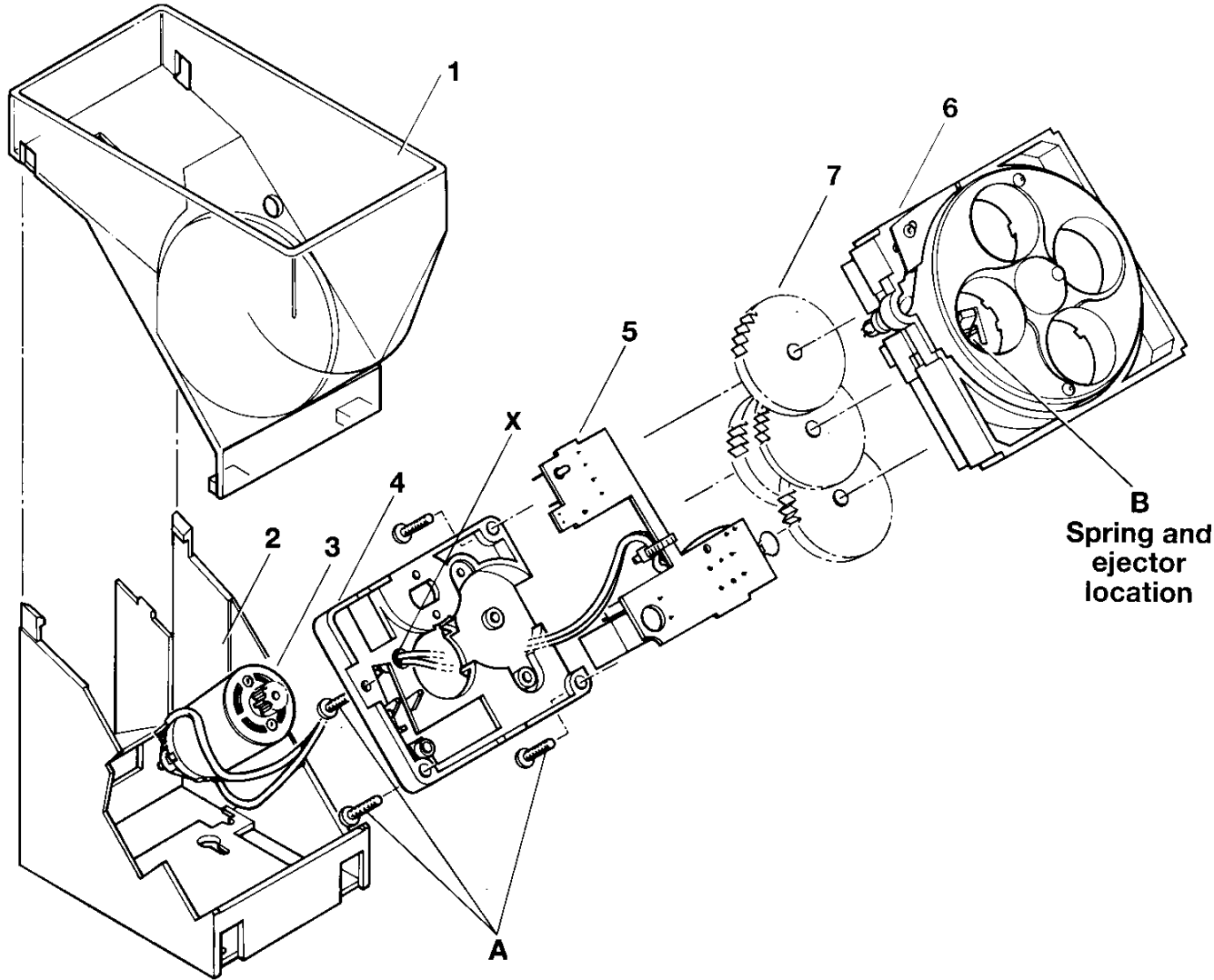

Parts List

1. Bowl
2. Base
3. Motor assembly
4. Gear box cover
5. PCB assembly
6. Disc bed assembly
(state coinage)
7. Gear cluster -
(Not serviceable item,
illustrated for reference only)

Note: When ordering motor assembly, gearbox cover, PCB assembly or disc bed assembly, screws are supplied separately.

The parts listed are the only user serviceable components available. All units requiring additional work should be returned to a Coin Controls group company or approved service centre.

Tampering will invalidate the warranty.

AC500 CABINET PARTS BREAKDOWN

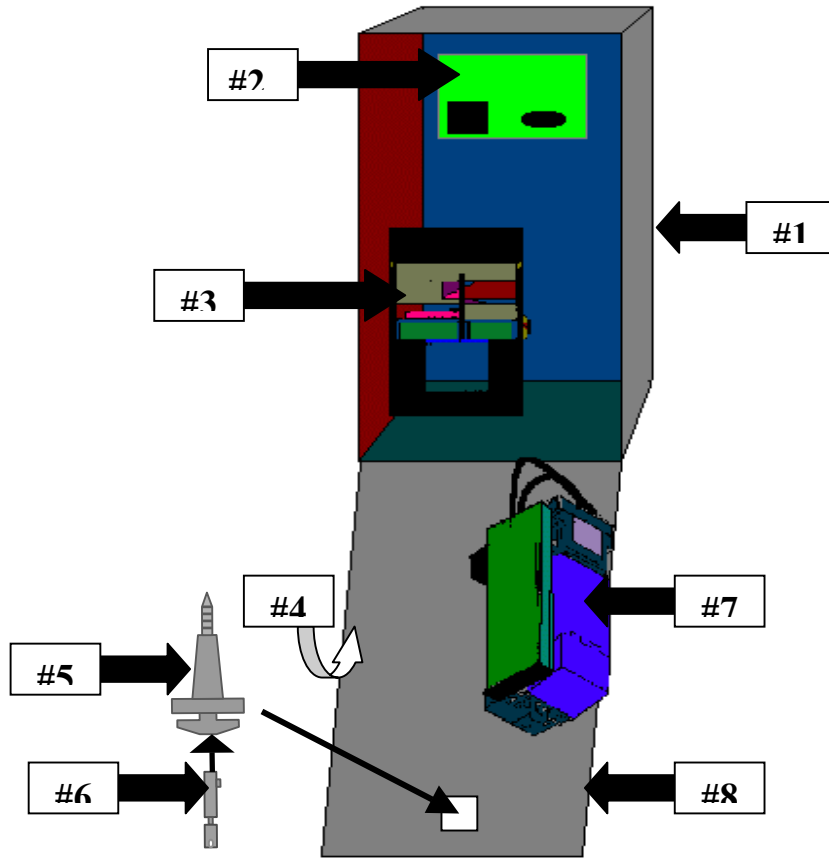

AC500 CABINET PARTS SHOWN

- #1 - AC5010 -CABINET W/DOOR AND LOCK NUT ASSY & COIN CUP
- #2 - AC5060 -AC500 MAIN LOGIC BOARD
- #3 - AC5040.1 -COIN CONTROLS COMPACT HOPPER
- #4 - AC5081 -\$1 & \$5 FULL FRONT STICKER
- #5 - AC5080 -SCREW -IN T-HANDLE
- #6 - AC1093 -LOCK AND 2 KEYS
- #7 - AC9001 -COINCO MAG50BAB BILL VALIDATOR
- #8 - AC5010.1 -DOOR FOR THE AC500

OPTIONAL PARTS NOT SHOWN

- AC1051- TWO OUTLET SURGE PROTECTOR
- AC1052- FOUR OUTLET SURGE PROTECTOR
- AC1091- TILT ALARM ONLY
- AC5070- BASE / PEDESTAL
- AC5075- HEADER

AC400 CABINET PARTS BREAKDOWN

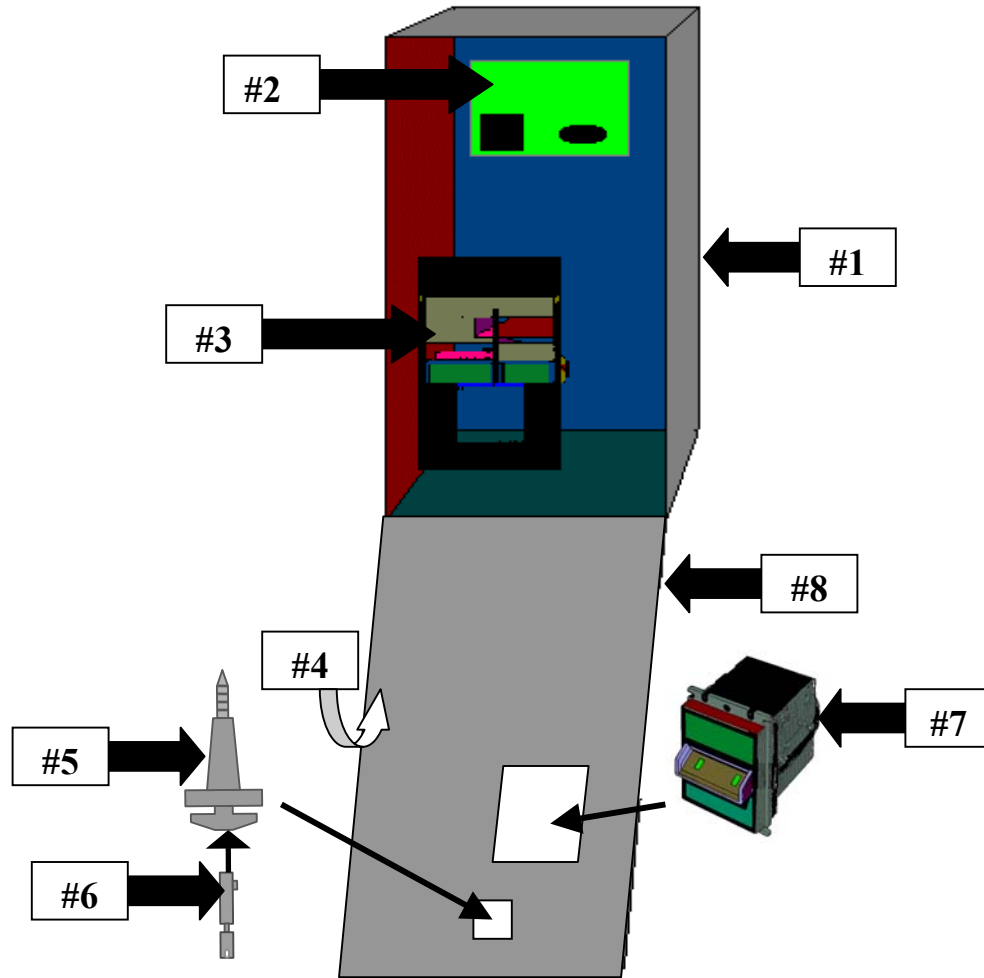

AC400 CABINET PARTS SHOWN

- #1 - AC5010 -CABINET W/ LOCK NUT ASSY & COIN CUP
- #2 - AC4060 -AC400 MAIN LOGIC BOARD
- #3 - AC5040.1 -COIN CONTROLS COMPACT HOPPER
- #4 - AC5081 -\$.00 FULL FRONT STICKER
- #5 - AC5080 -SCREW -IN T-HANDLE
- #6 - AC1093 -LOCK AND 2 KEYS
- #7 - AC9050 -JCM DBV-10 BILL VALIDATOR
- 38 - AC5009.1 -DOOR FOR THE AC400

OPTIONAL PARTS NOT SHOWN

- AC1051- TWO OUTLET SURGE PROTECTOR
- AC1052- FOUR OUTLET SURGE PROTECTOR
- AC1091- TILT ALARM ONLY
- AC5070- BASE / PEDESTAL
- AC5075- HEADER

COINCO PARTS LIST

MOUNTING ASSEMBLY PARTS BREAKDOWN

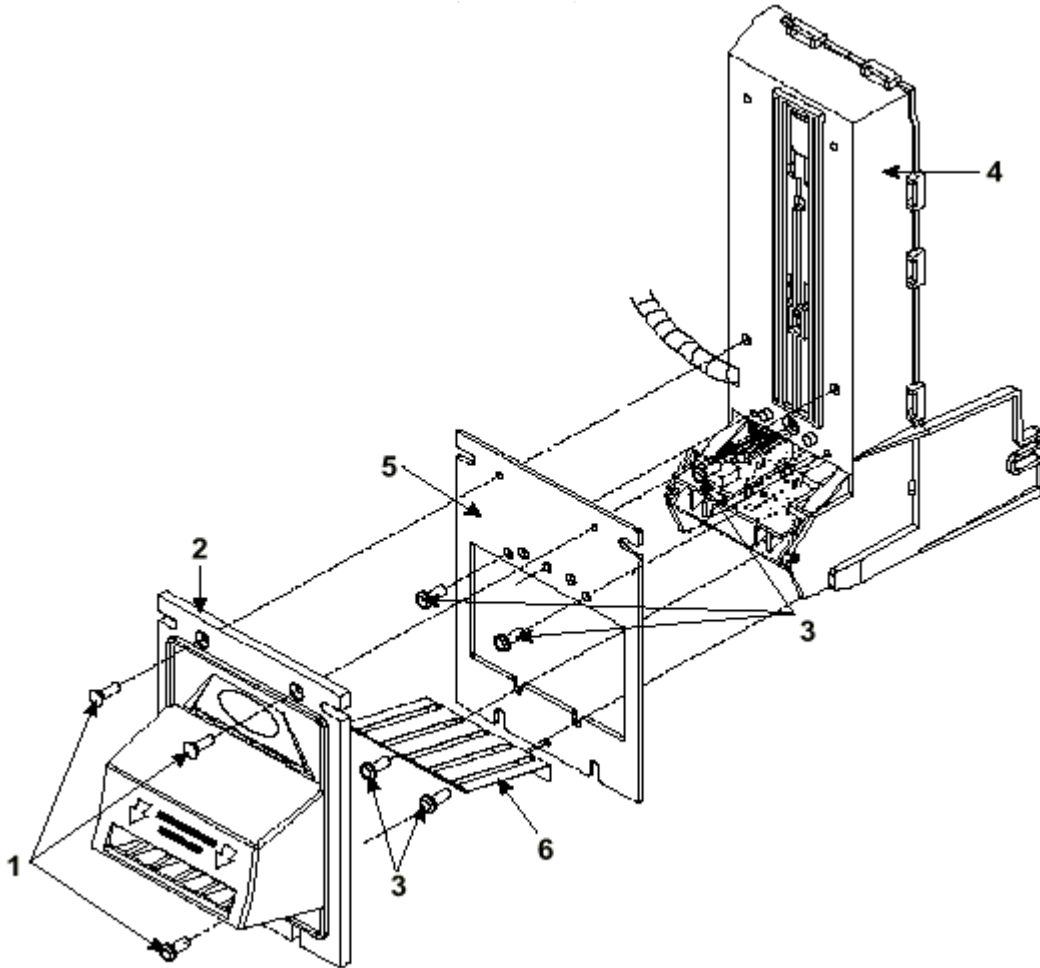

<u>PICTURE #</u>	<u>PART #</u>	<u>DESCRIPTION</u>
#1	MP90-1-1	Machine Screw
#2	MP90-1-2	"Snack Mask" Black Plastic
#3	MP90-1-3	Machine Screw
#3	MP90-1-4	Main Frame, Plastic
#4	MP91-1-5	Mask Gold Mounting Bracket
#5	MP90-1-6	Bill grounding spring
#6	MP91-1-7	Machine Nut
#7		

COINCO PARTS BREAKDOWN

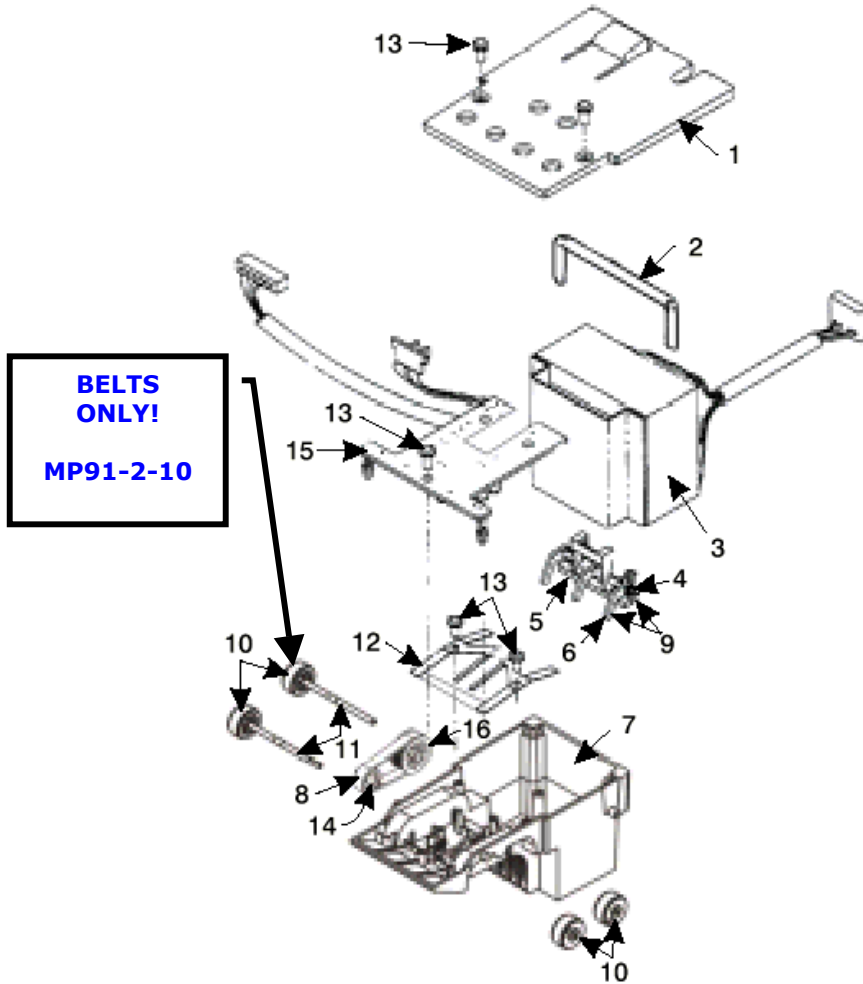

<u>PICTURE #</u>	<u>PART #</u>	<u>DESCRIPTION</u>
#1	MP90-2-1	Bottom Lower Housing Cover
#2	MP90-2-2	Transformer holding hose
#3	MP90-2-3	120VAC Transformer
#4	MP90-2-4	Lower Spring, Anti-Cheat Lever
#5	MP91-2-5	Lower Mounting, Anti-Cheat Lever
#6	MP90-2-6	Lower Anti-Cheat Lever
#7	MP90-2-7	Lower Housing Assembly, Complete
#8	MP90-2-8	Belt, Center
#9	MP90-2-9	Lower Anti-Cheat Assembly, Complete
#10	MP90-2-10	Plastic Wheels & Rubber Belts
#10	MP91-2-10	Rubber Belts ONLY (Each)
#11	MP90-1-11	Shaft, Drive
#12	MP90-2-12	Spring, MAG
#13	MP90-2-13	Screw, #4, Plastic
#14	MP90-2-14	Roller, Idler
#15	MP91-2-15	Sensor Board, Lower
#16	MP91-2-16	Pulley & Hub Assembly, Complete

COINCO PARTS BREAKDOWN

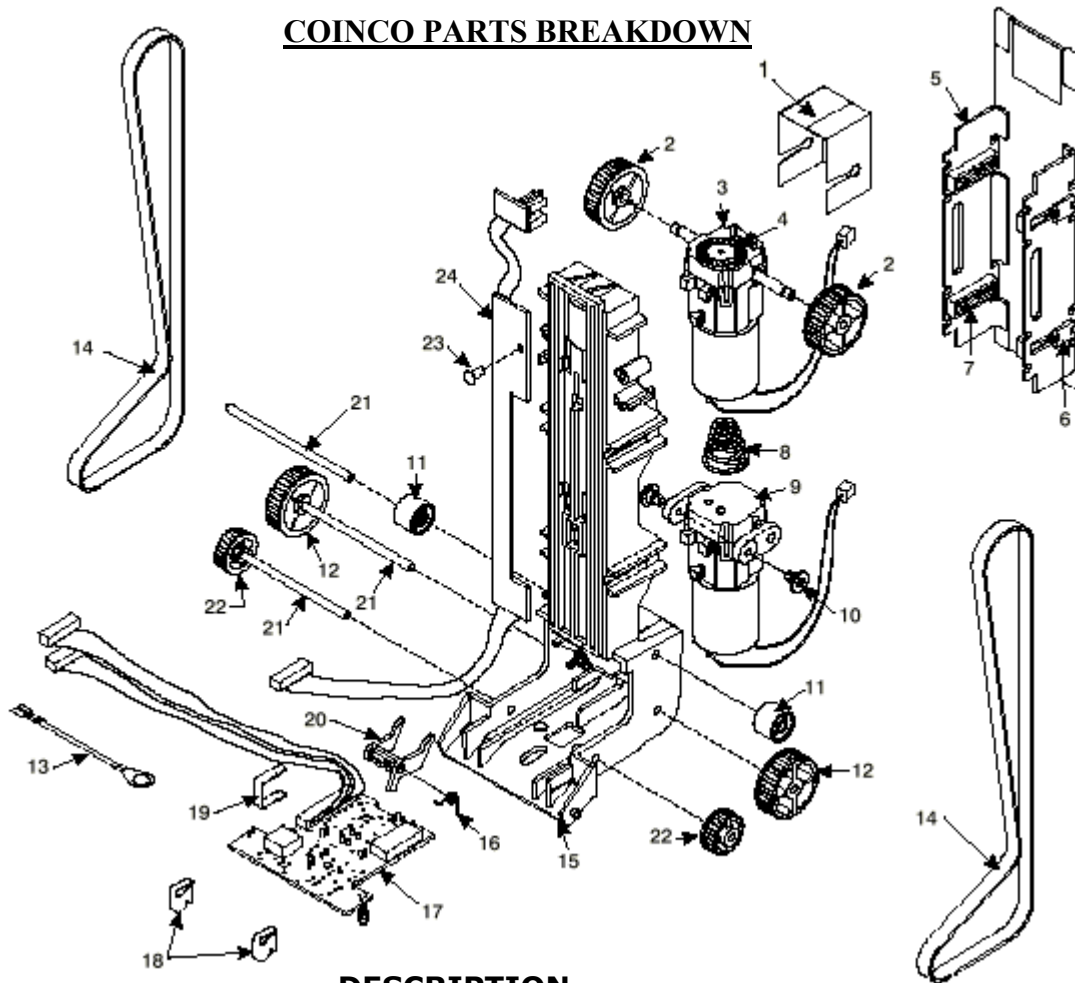

<u>PICTURE #</u>	<u>PART #</u>	<u>DESCRIPTION</u>
#1	MP90-3-1	Dust Cover
#2	MP90-3-2	Upper Transport & Hub Assembly, Complete
#3	MP91-3-3	Motor, Transport & Gear Assembly Complete
#4	MP90-3-4	Wheel, Encoder
#5	MP90-3-5	Stacker, Push-Plate Assembly
#8	MP90-3-8	Spring, Belt Tension
#9	MP90-3-9	Motor, Stacker Assembly Complete
#10	MP90-3-10	Pulley, Idler
#11	MP90-3-11	Lower Transport Pulley & Hub Assembly
#13	MP90-3-13	Belt, Upper Housing
#14	MP90-3-14	Frame, Upper Housing
#15	MP91-3-15	Sensor Board, Upper Housing
#16	MP90-3-16	Upper Board Clip
#17	MP90-3-17	Wire Clip
#18	MP90-3-18	Shaft, Pulley
#19	MP90-3-19	Shaft, Wheel
#21	MP90-3-21	Board, Stacker

COINCO PARTS BREAKDOWN

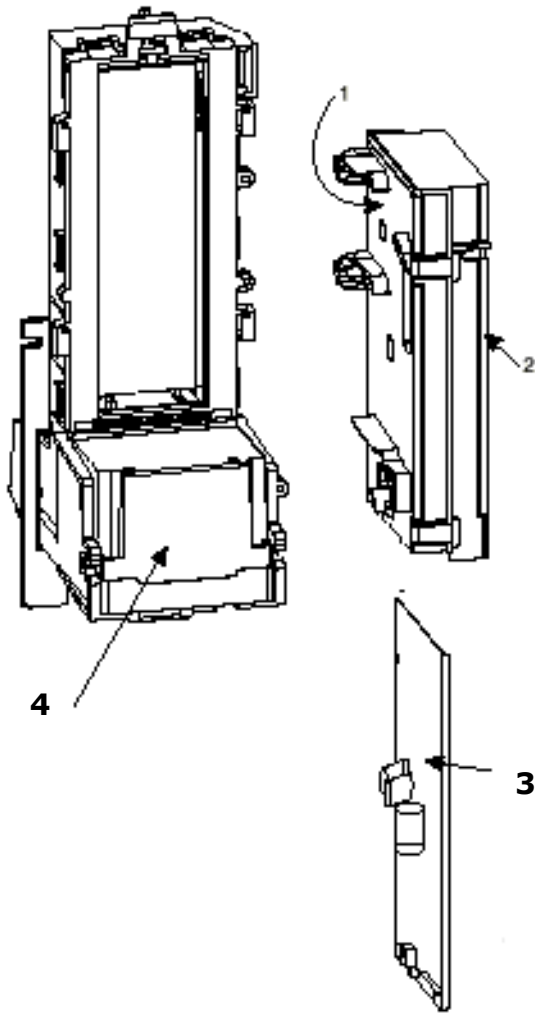

INTERMEDIATE FRAME ASSEMBLY

MP90-4-IF

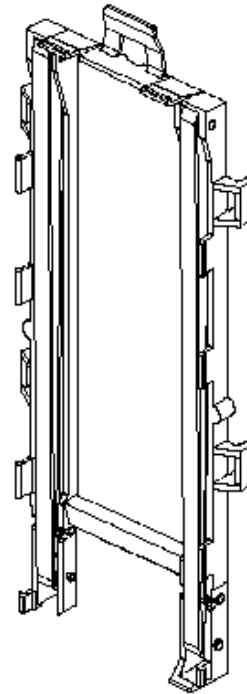

<u>PICTURE #</u>	<u>PART #</u>	<u>DESCRIPTION</u>
#1	MP90-4-1	Lid, Logic board Box
#2	MP91-4-2	Body, Logic board Box
#3	MP90-4-3	Main Logic Board
#4	MP90-4-4	Sticker, Serial Number / Warranty
#5	MP90-4-IF	Intermediate Frame with Bearings



CoinCo Authorized Service Centers

Arizona

3226 S. Fair Lane
Tempe, AZ 85282
Phone: 602-431-0632
Chris Mattingly

California

11618 E. Washington Blvd.
Suite # J
Whittier, CA 90606
Phone: 562-692-3059

FLORIDA**Tampa**

6704 Benjamin Road
Suite 200
Tampa, FL 33634
Phone: 813-249-7338
Bob Wilcox

Ft. Lauderdale

American Changer
1400 NW 65th Place
Ft. Lauderdale, FL 33309
888-741-9840
RMA # Needed

Georgia

4215 Wendall Dr SW
Suite # E
Atlanta, GA 30336
Phone: 404-691-2777
Chuck Crockett

Illinois

862 Eagle Dr.
Bensenville, IL 60106
Phone: 630-860-2650
Mike Durec

Louisiana

524 Elmwood Pkwy
Suite 190
Harahan, LA 70123
Phone: 504-734-0280
Frank Case

Maryland

6655 Amberton Drive
Bay "L"
Baltimore, MD 21227
Phone: 410-379-2680
Bill LeJune

Massachusetts

60 Prospect Street
Waltham, MA 02453
Phone: 781-894-4525
Kevin Cole

Missouri

1236 Dielman Industrial CT
St Louis, MO 63132
Phone: 314-725-0100
Charlie Pavia

Ohio

225 Corporate Court
Suite I
Fairfield, OH 45014
Phone: 513-874-4460
Joe Steddum

TEXAS**Dallas**

3031 Quebec Street
Suite 115
Dallas, TX 75247
Phone: 214-638-3970

Houston

2500 Central Parkway
Suite "K"
Houston, TX 77092
Phone: 713-683-6558
Steve TenBarge

Washington

1020 Industrial Drive
Bldg. 32
Seattle, WA 98188
Phone: 206-575-1999
Carl Goodson